



MARINE SERVICE TOOLS



ELECTRICAL



ENGINE



FUEL



GREASE GUNS



HOSE



IGNITION



DRIVE



PURGING



DRILL JIGS



ELECTRICAL TOOLS

ELECTRICAL

TOOLS CATALOG



18-9801 MULTI METER/DVA TESTER



Replaces: Mercury Marine 91-99750A1

- Includes VOA meter with built-in direct voltage adapter
- Tests electrical and ignition systems



18-9904 FAULT FINDER

A specially designed tool for tracking and tracing short and open circuits, broken wires and current leaks on any electrical circuit with voltages from 6 to 42 Volt DC. The automatic open/short detection, adjustable sensitivity and flexible antenna probe enables the technician to troubleshoot a complete array of common electrical problems without having to untie wire harnesses or remove panels.

- 8 in. flexible probe reaches in congested places
- Adjustable sensitivity
- Transmitter and receiver LEDs signal open or short circuit conditions
- Auto polarity transmitter that leads with 5 amp alligator clips
- Includes 18-9906 Cordless Circuit Tester & 18-9907 Fuse Socket Test Connectors
- Includes hard shell carrying case



Top View

18-9906

CORDLESS CIRCUIT TESTER

A computer safe, all solid state electronics circuit tester. Unlike regular test lights, this high-impedance circuit tester is safe to use around computers, electronics, ecm's and sensors. Rugged, built to last and simple to use, it requires no wire or clip connector to ground. The Cordless Circuit Tester's light and sound indicators allow users to check for power in less time that it takes to set-up a regular test light and find a suitable ground.

- No ground or clip necessary
- Range of operation: 3 to 28 VDC
- Powered by one AA alkaline battery
- Wireless design eliminates tangles



18-9907

FUSE SOCKET TEST CONNECTORS

A new and innovative fuse socket connector set, consisting of three connectors sizes: Mini, ATO and Maxi to cover the most common fuse socket adapters requirements in the electrical repair field.

- Maximum conductivity and durability.
- Molded for easy insertion and removal.
- Easy access connector tabs fit :
 - ¼" quick connects
 - Alligator clips
 - Jumper Leads
 - Multimeter test leads



18-9911

REFLECTIVE TAPE

A package of (6) specially formulated self adhesive reflective tape strips, for use as a target for optical tachometers. Its highly reflective surface is designed to scatter the light (infrared, laser or visible) emitted by the optical tachometer, improving the detection of the rotating or moving object from a wide range of angles and distances.

- Size: 8" (L) x 0.2" (W) / 20 cm (L) x 0.5 cm (W)
- High performance self adhesive backing
- Wide angle reflectivity material
- Specially made for use with optical and laser tachometers and counters

18-9912**LASER TACHOMETER & COUNTER**

Measures and tests the number of rotations per minute (RPM) or total number of rotations or events on any spinning shaft, pulley, wheel, drive belt, fan, or other rotating objects in general, safely, accurately and easily due to its unique ergonomic design.

- Measures from 2.5 to 99999 RPM
- 0.05% accuracy
- 2 to 20" measuring range
- Laser-powered optical system
- Memory recall functions (minimum & maximum)
- Large LCD display with symbols and backlight
- On target display indicator
- RPM, Total revolutions, maximum, minimum and last reading memory

**18-9905****AC/DC LOW CURRENT CLAMP METER**

Designed to accurately measure current, current leaks (parasitic draws down to 1mA) and electrical loads from 1mA to 100 amp AC/DC and voltages from 0 to 600 AC/DC. The small diameter (1/2 inch or 13mm) and narrow jaw makes it ideal for use in confined spaces and on small gauge wires. Other features include resistance measurement functions, audible continuity test, display hold and peak detector.

- Large 4 digit LCD display
- Clamp opens up to 1/2" (12.5 mm)
- Operates with one rotary switch
- One touch auto zero
- Test leads and batteries included
- Includes soft shell carrying case

**18-9908****AC/DC 600A CLAMP METER**

Allows the measurement of AC/DC currents with a resolution down to 0.1 A, and up to a maximum of 600A, making it ideal for testing all kinds of loads such as found in: electric motors, fuel pumps, charging systems, starter currents, alternators, etc.

- Voltage measurement: up to 600 V
- Clamp opens up to 1" (25.4 mm)
- Large 4 digit LCD display
- Operates with one rotary switch
- One touch auto zero
- Continuity check with audible indicator
- Test leads and batteries included
- Includes soft shell carrying case





18-9909

PROFESSIONAL MARINE DIGITAL MULTIMETER

CARRYING CASE INCLUDED

Offers full auto range features and functionality. Equipped with a 4 digit LCD display with analog bar graph it is capable of measuring AC/DC voltage up to 600 Volt and AC/DC current up to 10 A. Other functions includes tachometer for RPM measurement, dwell, temperature, resistance, frequency, fuel injection test, diode test, continuity check and overload protection.

- State of the art design and styling for easier handling and use
- Large 4 digit LCD display with analog bar graph
- Tachometer function measures 30 to 20000 RPM.
- Temperature measurement from -20°C to 500°C or 0° to 932°F
- Resistance measurement up to 40 MOhm
- Frequency measurement from 10 to 20 KHz
- Comes with hard shell carrying case



18-9910

OXYGEN SENSOR TESTER & SIMULATOR

CARRYING CASE INCLUDED

Provides a simple interface for test and diagnostic on any oxygen sensor, to quickly determine whether the sensor is defective and needs replacement. It is designed as both a stand-alone tool or as a complement to any scanner during the diagnostic process, and is compatible with all types of Oxygen sensors.

- Signal output shown in real time on LED bar graph
- 2 button simulation of rich or lean conditions to monitor response of the engine control module
- Auto detection of common wire misconnections
- Diagnoses “lazy” (slow response) sensors, which may not set DTCs, but cause drivability problems
- By pressing the ‘Test’ button and performing a snap throttle acceleration of the engine, it tests the response time of the sensor and shows a pass or fail result within seconds
- Works with zirconium, titanium & air/fuel ratio sensors
- Comes with hard shell carrying case



18-9913 SMARTACH

CARRYING
CASE
INCLUDED

Designed for use on any engine equipped with an alternator, and only requires a simple connection to the electrical system (e.g. battery, alternator, cigarette lighter connector) to measure engine RPM. Taking advantage of the ripples generated by the alternator, SMARTACH automatically calculates the relationship between the speed of the engine and the alternator ripples, and uses them to measure RPM on any piston engine regardless of its ignition system (Diesel or gasoline).

- Measures from 2.5 to 99999 RPM
- 0.05% accuracy
- 2 to 20" measuring range
- Laser-powered optical system
- Large 4½ digit LCD display
- For 1 to 12 cylinders and 2 or 4 cycle engines
- Memory recall functions (minimum & maximum)
- Comes with hard shell carrying case



ENGINE TOOLS



18-9800 COMPRESSION TESTER

Perfect for hard to reach bottom spark plug holes on older Mercury models.



18-9902 DEEP WELL COMPRESSION TEST ADAPTER

For deep well spark plug holes to perform compression testing. Works with 18-9900 compression tester.

- 14mm and 18mm threads
- Reaches 8" beyond the installation surface



18-9900

DIGITAL COMPRESSION TESTER

For testing compression on gasoline powered engines.

- Stores max compression value for up to 12 cylinders
- Backlit LCD Display
- Auto Shutoff
- Sealed and Vibration protected
- Displays values in PSI, Bar, and kPa
- Fits many outboard, inboard, PWC, ATV, recreational gasoline engines



OIL FILTER WRENCHES

Sierra Oil Filter Wrenches are used to replace screw-on type canister oil filters and fuel filters on a variety of outboard engines. This formed metal tool has a pivoting handle and tempered metal band for superior strength and durability.

Part No.	Size
18-9778	Size: 2-7/16" thru 3"
18-9789	Size: 2-9/16" thru 3-1/4"
18-9790	Size: 3-5/16" thru 3-3/4"



18-4442

ENGINE ALIGNMENT TOOL

Replaces: Mercury Marine 91-57797A3, 91-57797A2, 91-57797A1, 91-8M0067546, 91-805475A1, 91-48347, 91-37384

Used to verify engine alignment on all Mercruiser, OMC Cobra, SX Cobra, and Volvo SX Sterndrives.



18-95560

ENGINE OIL PRIMER

• Used to prime the engine oil pump after replacement



18-79817

UNIVERSAL ENGINE PULLER

• Mounts to 2 and 4 bbl manifolds to lift engine



18-79834

LIFTING EYE TOOL

For: Lifting Johnson/Evinrude V4 & V6 engines



18-79833

FLYWHEEL PULLER TOOL

Replaces: Mercury 849154T1

• Removes flywheel from many Mercury Outboard engines



18-9897

**VERADO FLYWHEEL PULLER/
LIFTING EYE**

Replaces: Mercury 91-895343T02,
91-895343T01, 91-895343A02

Fits: All Verado engines as a lifting eye
and flywheel puller



18-9896

LIFTING EYE TOOL

Replaces: Mercury 91-904551, 91-90455TI,
91-90455T, 91-878232, 91-75132, 91-47448A1

For: Lifting many Mercury Outboard Engines



18-9798
2-STROKE OIL MIXING BOTTLE

32 FL. OZ re-usable bottle for precise measuring of oil to fuel ratio for your engine

18-9780
FLEXFILL SPOUT

• For easy pouring from quart bottles

 **FUEL TOOLS**



18-8600
E-GO! FUEL INJECTION CLEANING KIT

For: Mercury, Honda, Yamaha
 • Cleans away layers of fuel deposits when the engine is running
 • Helps maintain the injector's cleanliness and performance throughout the life of your engine
 • For best results, use 18-8606 E-GO! Blast Fuel Injector Cleaner

Contains:
 Cleaning System Container, Hose, Small Fitting, Large Fitting, Carrying Case

18-79815
FUEL FILTER TOOL

Replaces: Yamaha YB-ACC04
 For: Yamaha FI50-F350, 2.6L & 3.3LHPDI (2006 & Up)



18-79814
FUEL FILTER TOOL

Fits Verado and Optimax engines equipped with VST castle nut type fuel filter



18-9884
BOWL WRENCH

Replaces: Racor RK22628
 • For all metal and Aqua-Vue™ collection bowls
 • Corrosion and impact resistant



18-79816
FUEL TESTER

Replaces: Mercury 91-879172T28
For: Tests quality of fuel by measuring alcohol content.



18-79816-24
FUEL TESTER DISPLAY PACK

Contains 24 of the 18-79816 fuel tester.



GREASE GUNS



18-9782
GREASE GUN

Replaces: Mercury 91-74057Q6
• 14 OZ. capacity
• Heavy duty steel construction for dependable, long service life



18-9785
EASY LUBER

Replaces: Mercury 91-30500
• Ideal for quick, easy lube jobs using squeeze tubes
• Compact, perfect for under seat/tackle box storage
• Use with all 10 oz. grease tubes



18-9783
GREASE GUN

Replaces: Mercury 91-74057Q6
• 3 OZ. capacity
• Heavy duty steel construction for dependable, long service life
• Display packaged



18-9804
GREASE GUN

• Designed for hand operated or pneumatic grease guns
• Ideal for hard to reach grease fittings
• 12 inch length. (304.8mm)
• Heavy duty with flex hose



HOSE TOOLS

18-79823

STEPLESS CLAMP 90 DEGREE TOOL

Fits: Crimp type stepless clamps



18-9898

HOSE PINCH-OFF PLIERS

• Use to pinch off rubber hoses up to 1 1/2" OD



18-9141

OETIKER JAW PINCERS

Replaces: Johnson/Evinrude 787145,
Yamaha YB-6AW04-4

Fits: Crimp type clamps



IGNITION TOOLS



18-8960

IGNITION SPARK TESTER

- Checks for ignition spark in up to 4 ignition wires at a time
- Adjustable spark gap
- Easy clip on ground wire



18-9802

TIMING LIGHT

- Replaces: Mercury Marine 91-99379
- Self-powered accurate up to 10,000 RPM's
 - Checks ignition timing
 - Powered by two "D" cell batteries
 - Portable



18-9903
ENGINE IGNITION ANALYZER

A handheld instrument designed from the ground up for the diagnosis and performance measurement of all types of spark ignition systems.

- Displays everything on a 3.5" color screen
- Rechargeable battery provides 6+ hours of use
- Durable design (MIL-STD-810) drop test approved
- Comes with hard shell carrying case
- Includes 18-9914 Plug Wire Sensor Clip and Extension Lead



18-9914
PLUG WIRE SENSOR CLIP EXTENSION

Extension Lead with Plug wire sensor clip for 18-9903

- For use with 18-9903 Engine Ignition Analyzer
- 2 m (78") long shielded cable with BNC connector
- Sensor accepts wires of up to 9 mm (3/8") diameter
- Cable can also be used with coil on plug sensor supplied with the 18-9903



DRIVE TOOLS



18-9847
BELLOWS EXPANDER TOOL

Replaces: Mercury Marine 91-45497A1

- Installs exhaust bellows on MC-I, R-MR, Alpha One, Bravo One and Two and Blackhawk drive units



18-9870

SLEEVE INSTALLATION TOOL

Replaces: Mercury Marine 91-818162

- Installs the aluminum sleeve into the u-joint bellows on Bravo, Alpha, and Blackhawk Drives



18-9871

SLEEVE REMOVAL TOOL

Replaces: Mercury Marine 91-818169T

- Removes the aluminum sleeve from the u-joint bellows of all Bravo, Alpha One/Gen II and Blackhawk drive units



18-79813

BEARING CARRIER PULLER TOOL

For: Mercruiser, Mercury and Yamaha

- Removes bearing carrier assembly from Yamaha 90-115HP Outboards



18-9858

BEARING CARRIER RETAINER WRENCH

Replaces: Mercury Marine 91-61069T

- Loosens and tightens the bearing carrier retainer nut on MC-I, R-MR, TRS, Alpha, Bravo I, and Bravo III drives



18-9809

BEARING CARRIER RETAINER TOOL

Replaces: Mercury Marine 91-17257

Description: Loosens and tightens bearing carrier retainer on Bravo Two drives.

18-52205

FLUID DISPENSER

Easily dispenses fluids for any application.

- Large 1.2 gallon capacity
- Sealed internal pump components
- Flow control valve equipped
- Quick connect fittings
- 20PSI Max Pressure
- Includes pressure gauge
- Integrated pressure relief valve





18-52206
FLUID DISPENSER/EXTRACTOR

For removing/dispensing fluid in difficult to reach areas.

- No-drip cap
- 7 oz. capacity
- 7 1/2" flexible tube



18-52207
TUBE KIT

Replacement tubes for oil extractors 18-52204 and 18-52104.



18-52204
OIL EXTRACTOR

For quick, easy & clean oil changes.

- Not only can this extract fluids, but it is capable of dispensing too
- Bi-directional valve can be moved to either create a vacuum or dispensary
- Built-in shut-off valve to prevent overfilling
- Comes complete with 5 feet of flexible hose and two rigid dipstick tubes.
- Size: Large 2.3 Gallon (8.8L) Capacity



18-52104
OIL EXTRACTOR

For quick, easy & clean oil changes.

- Can be used to remove a wide range of fluids, such as engine oil, brake fluid, antifreeze, and more
- Built-in shut-off valve to prevent overfilling
- Can be used away from the air source by creating a vacuum, closing off both shut-off valves
- Comes complete with 5 feet of flexible hose, 2 rigid dipstick tubes, and a brake bleeding kit
- Size: 2.3 Gallon (8.8L) capacity air operated extractor



18-9781 OIL PUMP

Replaces: Mercury 91-850730Q01, 91-8M0072133

- Ideal for "do-it-yourself" owners
- Quart size application is perfect for most marine drives
- Includes lube fitting for domestic lower units with flexible fill line



18-9784 OIL PUMP

Fits: 16 thru 55 gallon drums



18-9788 LUBE PUMP

For filling lower units on outboards and stern drives.

- Tapered/unthreaded hose end
- Size: 5 Gallon (18.95L)



18-81006 GREASE FILLER ADAPTER

Fits: OMC and Volvo dual prop gearcases



LOWER UNIT FILL TUBE 18-9786 (STANDARD) 18-9787 (IMPORT)

- Flush & fill tool for small gearcases requiring the 10 ounce tube package
- Ideal for "do-it-yourself" in home maintenance
- 18-9786 fits Mercury. 18-9787 fits most import outboards



18-9794 GEAR LUBE ADAPTER

Replaces: Mercury 91-883704Q03

For: Nissan, Yamaha, Honda, Tohatsu

- For use with Sierra quart pumps or lower unit fill tubes
- Metric 8-1.25 thread



18-9795 GEAR LUBE ADAPTER

For: Suzuki lower units.

- For use with Sierra quart pumps or lower unit fill tubes
- Metric 10-1.25 thread



18-8997
DUAL FEED FLUSH - ROUND CUPS

Universal
 • Fits most engines up to 115 H.P.



18-8998-1
**ENGINE FLUSHER
 (RECTANGULAR CUPS)**

Universal
 • Fits most engines 120 H.P. and UP



18-8999
**DUAL FEED FLUSH
 (RECTANGULAR CUPS)**

• Fits most engines 120 H.P. and UP



18-9009
INBOARD FLUSHER

Universal
 • Fits most inboard engines



18-9010
**MOTOR FLUSHER
 (HEAVY DUTY)**

- High quality EPDM rubber cups
- Corrosion resistant dicromate finish
- Installs in seconds
- Use with a standard garden hose
- Hose connector complete with rubber washer
- No tools required



18-9895
DUAL WATER PICKUP SEAL

Replaces: Mercury/Evinrude 881150K1
 • Fits Mercury and E-tec engines
 • Blocks off the front water inlet holes on the dual water inlet gearcases



18-9850
BACKLASH INDICATOR

Replaces: Mercury Marine 91-53459
 • Checks gear backlash on TR, TRS, MC-I, R-MR, Alpha One, Alpha One/Gen II and Bravo One and Two drive units



18-9866
DIAL INDICATOR HOLDING TOOL

Replaces: Mercury Marine 91-89897
 • Secures dial indicator to gear housing when checking backlash on TR, TRS, MC-I, R-MR, and Alpha One Stern drive units and Outboards



18-79820-1
GIMBAL PULLER TOOL

For: Mercruiser, OMC and Volvo.
Sometimes the gimbal bearing can be a real pain to remove. This tool is designed to get the toughest gimbal bearing out of Mercruiser, OMC, and Volvo Penta Sterndrives.



18-79825
GIMBAL BEARING INSTALLER TOOL

For: Mercruiser, OMC and Volvo Penta SX sterndrives
• Use with 18-4442 Alignment tool



18-9861
HINGE PIN TOOL

Replaces: Mercury Marine 91-78310
• Removes and installs hinge pins from all Mercury Marine drive units



18-9840
PULLER

Replaces: Mercury Marine 91-38919
• Removes swivel pins from R-MR and Alpha One gimbal rings



18-9859
PULLER

Replaces: Mercury Marine 91-63616
• Removes swivel pin from Alpha Gen II and All Bravo Gimbal Rings



18-9838
U-JOINT ADAPTER

For: Mercury 91-38756
• Supports yoke when disassembling u-joint on all drive units EXCEPT Bravo II and Bravo III



18-9841
DRIVE SHAFT SHIMMING TOOL

For: Mercury 91-42840T
• Shims pinion gear on Bravo One drives



18-9842
DRIVE SHAFT RETAINER WRENCH

Replaces: Mercury Marine 91-43506T
• Removes and installs threaded bearing retainer under the water pump housing on Mercruiser sterndrives and Mercury Mariner outboards



18-9857
PINION NUT ADAPTER

Replaces: Mercury Marine 91-61067A3
 • Holds pinion nut when removing pinion gear and drive shaft on MC-I, R-MR, and Alpha One Stern drive units and Outboards



18-9865
DRIVE SHAFT BEARING TOOL

Replaces: Mercury Marine 91-90774
 • Presses bearing cone onto Alpha One/Gen II drive shaft housing pinion gear



18-9874
DRIVE SHAFT PRELOAD TOOL

Replaces: Mercury Marine 91-14311A2, 91-44307A1, 91-14311A04, 91-14311A1
 • Preloads drive shaft bearing when checking pinion height and backlash
 • Compatible Drive Units and Outboards: MC-I, R-MR, Alpha One, Alpha One/Gen II



18-9875
PULLER ASSEMBLY

Replaces: Mercury Marine 91-90244A1
 • Removes and installs drive shaft housing bearings and sleeves on all Bravo drive units



18-9854
DRIVE SHAFT ADAPTER

For: Mercury 91-56775T
 • Provides a wrench surface to turn the drive shaft on Mercruiser MC-I, R-MR, Alpha drive units and many outboard engines with a 13 spline drive shaft



18-9868
DRIVE SHAFT ADAPTER

Replaces: Mercury Marine 91-61077
 • Provides a wrench surface to turn the drive shaft on Mercruiser MC-I, R-MR, Alpha, Bravo I, and TRS drive units



18-9843
CLAMP PLATE

For: Mercury 91-43559
 • Installs onto the gear housing while separated from the driveshaft housing and holds a preload while checking the gear backlash and bearing preload on Bravo I and Bravo II Drives



18-9872
PUMP ALIGNMENT TOOL

For: Mercury 91-821571A1
 • Aligns Alpha One/Gen II water pump during installation



18-9844

TAPERED INSERT TOOL

Replaces: Mercury Marine 91-43579
 • Installs tapered insert retainer into water inlet hose on all Bravo drive units



18-9817

SHIFT SHAFT BUSHING TOOL

Replaces: Mercury Marine 91-31107T, 91-31107, 91-24150, 91-23033T, 91-23033
 • Removes and installs the shift shaft bushing in the gear case of drive units and outboards on MC-I, R-MR, and Alpha One drives



18-9812

BEARING & SEAL INSTALLATION TOOL

For: Mercury 91-17275A1
 • Installs the shift shaft bushings and oil seal on all Bravo and Blackhawk drives



18-9879

INTERMEDIATE SHIFT CABLE SNAKE

For: Mercury 91-821571A1
 • Use to easily remove and install intermediate shift cables in Mercruiser drives



18-95605

SAFETY WIRE TWIST PLIERS

• Includes cutter, wire twister, and heavy-duty pair of pliers



18-9806E

SHIFT CABLE TOOL

For: Mercury 91-12037
 • Installs and removes shift cables on MC-I, R-MR, Alpha One, Alpha One/Gen II drive units



18-9807

SHIFT CABLE ADJUSTMENT TOOL

For: Mercury 91-12427, 91-12427T
 • Used for proper Bravo drive unit shift cable adjustment at the shift plate



18-9810

SHIFT CABLE ANCHOR ADJUSTMENT TOOL

For: Mercury 91-17262A1
 • Used to install shift cable core wire on all Bravo drive units



18-4444
PROP WRENCH

For: Mercury, Mariner, Force V4 & V6, Honda BF75-BF115, and all Mercruiser
Replaces: Mercury 91-95830A1, 91-95830, 91-38277A1
• Prop wrench for prop nuts 1 1/16"



18-4459
PROP WRENCH

Replaces: Mercury 91-821887A1, 91-859046Q4, 91-859046T4
• Prop wrench for prop nuts 1 1/16"



18-9803
SPANNER NUT WRENCH

Replaces: Mercury Marine 91-17256
• Removes and installs driveshaft bearing retainer on MC-I, R-MR, Blackhawk, all Bravo and all Alpha drive units.

ADDITIONAL DRIVERS

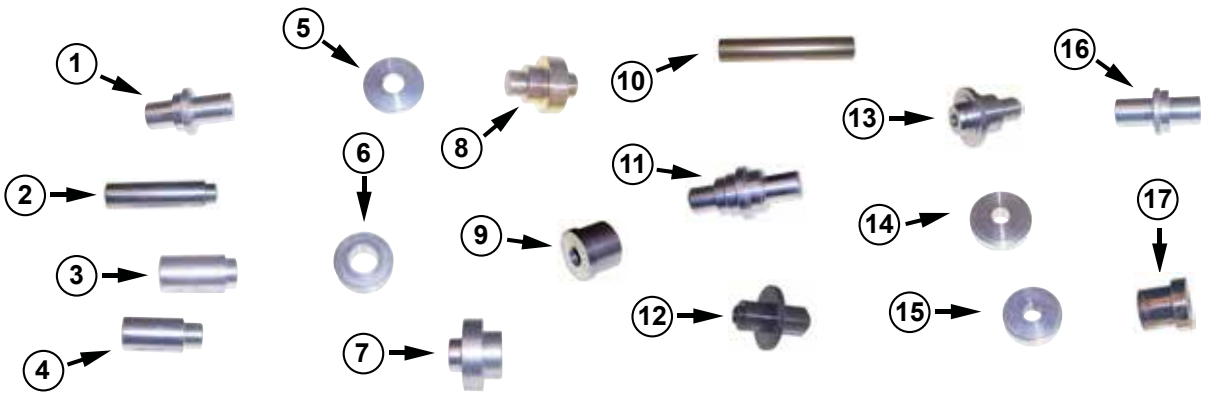

	Part No.	Mercury Part No.	Description
1	18-9818	91-31108T, 91-31108	Oil Seal Driver
2	18-9823	91-33489	Driver Head
3	18-9824	91-33491	Driver Head
4	18-9825	91-33492T, 91-33492	Driver Head
5	18-9826	91-33493, 91-33493T	Bearing Cup Driver
6	18-9827	91-34379T	Bearing Cup Driver
7	18-9845	91-43591T	Seal Driver
8	18-9846	91-44110	Seal Driver
9	18-9860	91-63638T	Bearing Driver

	Part No.	Mercury Part No.	Description
10	18-9862	91-87119	Bearing Driver
11	18-9863	91-89865	Bearing Driver
12	18-9869	91-817570T	Upper DriveShaft Housing Seal Driver
13	18-9873	91-813653	Bearing Driver
14	18-9831	91-36577, 91-36577T	Bearing Cup Driver
15	18-9839	91-38918T	Bearing Cup Driver
16	18-9851	91-55916	Oil Seal Driver
17	18-9852	91-55918	Bearing Driver

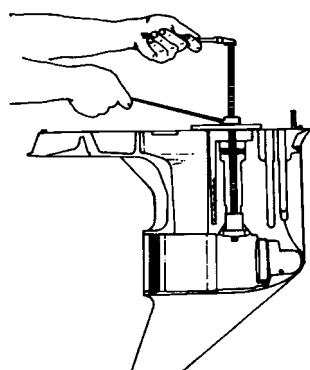

18-9820 BEARING INSTALLATION TOOL KIT

Replaces: Mercury Marine 91-31229A7
Removes and installs bearings in MC-I, R-MR, Alpha One, Alpha One Gen II and all Bravo gear cases.

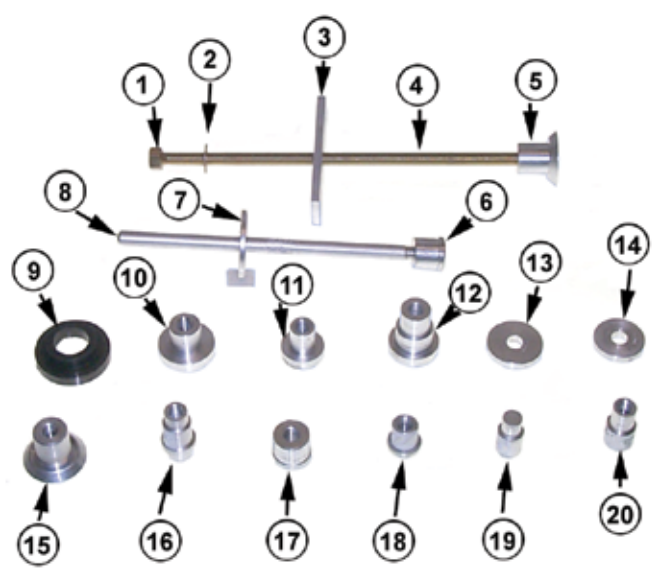

CONTAINS:

Part No.	O.E. No.	Description	Part No.	O.E. No.	Description		
1	NSS	11-24156	Puller Nut	11	18-9837	91-38628T	Puller/Driver Head
2	18-9805	12-34961	Puller Washer	12	18-9808	91-15755T	Needle Bearing Driver
3	18-9814	91-29310	Puller Plate	13	18-9830	91-36571T	Pilot Washer
4	18-9819	91-31229	Puller Shaft	14	18-9836	91-37350	Washer
5	18-9821	91-32325T	Driver Head	15	18-9849	91-52394	Bearing Puller
6	18-9848	91-52393	Driver	16	18-9832	91-37292	Bearing Puller
7	18-9815	91-37324	Pilot Plate	17	18-9822	91-32336	Driver Head
8	18-9835	91-37323	Driver Rod	18	18-9829	91-36569T	Driver Head
9	18-9816	91-30366T1	Mandrel	19	18-9833	91-37311	Driver Head
10	18-9828	91-36379	Driver Head	20	18-9834	91-37312	Driver Head



18-9853 PINION GEAR SHIMMING TOOL

Replaces: Mercury 91-56048T, 91-56048001
• Measures the pinion height of MC-I, R-MR, and Alpha Drives



18-9855 DRIVEN GEAR SHIMMING TOOL

Replaces: Mercury 91-60523
• Measures the upper drive gear clearance on MC-I, R-MR, and Alpha drives



18-9856 DRIVEN GEAR SHIMMING TOOL

Replaces: Mercury 91-60526T
• Measures the upper driven gear clearance on MC-I, R-MR, and Alpha drives

OMC SHIMMING TOOLS

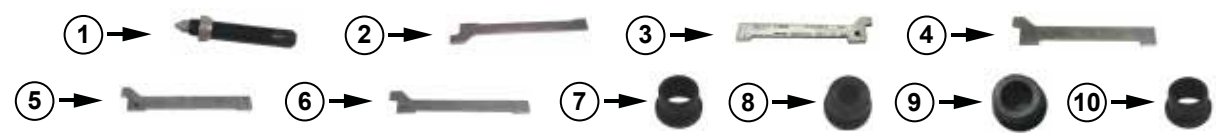

Part No.	OMC Part No.	Description	Part No.	OMC Part No.	Description		
1	18-9894	393279	Pressure Screw	6	18-9891	328367	Gauge Bar
2	18-9876	349957	Gauge Bar	7	18-9885	328360	Collar
3	18-9888	328364	Gauge Bar	8	18-9886	328361	Collar
4	18-9889	328365	Gauge Bar	9	18-9887	328363	Collar
5	18-9890	328366	Gauge Bar	10	18-9892	341440	Collar



PURGING TOOLS

PURGING

TOOLS CATALOG



HA5445-2

SEASTAR POWER PURGE JR

The EASY way to 100% purge air out of BayStar and SeaStar hydraulic steering systems. The Power Purge Jr. reduces installation and warranty costs while enhancing the quality of the boat to the end user. A typical manual fill and purge takes the average experienced installer or service technician about 30 minutes per boat — by using the Power Purge Jr. this can be reduced to 10 minutes or less.



Features:

- Steering feel is solid every time
- 100% portable
- Powered by 12v battery
- Fast and efficient set up
- Quick connect fittings
- Easy to operate
- Filter screens help keep contamination out of your steering system
- Complete Fill & Purge in 10 minutes or less
- Optional Dual Cylinder Purging Kit HA5461 available

HA5456

SEASTAR POWER STEERING PURGE KIT

25' hose to connect steering cylinder to reservoir for bleeding.

- Makes bleeding even easier than before.



HA5457

SEASTAR POWER STEERING PURGE KIT

Central bleeding location — no need to run hoses to reservoir.

- Makes bleeding even easier than before.





DRILL JIGS

HA5466

ROUND DRILL JIG

Drill jig for drilling mounting holes for standard SeaStar and SeaStar Pro helms. A three inch dashboard hole is required. Use with HA5465.



HA5467

ROUND DRILL JIG

Drill jig for drilling mounting holes for standard SeaStar and SeaStar Pro helms where dashboard has a 3-1/4 inch hole from a previously mounted mechanical helm.



HA5468

SQUARE DRILL JIG

Drill jig for drilling mounting holes for standard SeaStar and SeaStar Pro Classic Tilt helms (HH6541-3, HH6542-3, HH6543-3). Also back Mount (HA5418). A 4-1/2 inch dashboard hole is required.



WANT FREE TOOLS? CHECK OUT OUR ONLINE VIDEOS!

WWW.SEASTARSOLUTIONS.COM/VIDEOS



© Copyright 2017 SeaStar Solutions All Rights Reserved
Document: Tools Catalog - 2017
Printed in the USA

Part No. CATALOG - TOOLS

